



Operating instructions

(Translation of the original operating instructions)

Spark separator

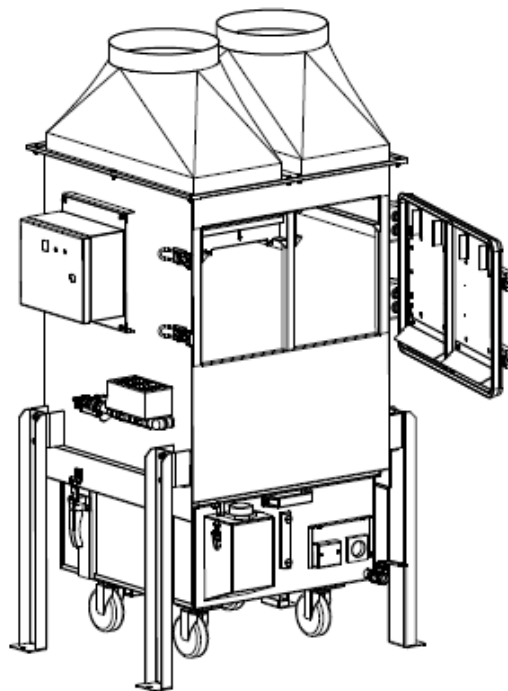



Table of contents

1. General	3
2. Description of the system elements	4
2.1. Illustration of the system elements	4
2.2. Intended use	5
3. Safety instructions	6
3.1. Definition of the hazard symbols	6
3.2. General safety instructions	6
4. Storage, transport and installation of the device	7
5. Commissioning	7
5.1. Connecting the suction line and exhaust air line	8
5.1.1. Positioning the perforated sheet	8
5.2. Electrical connection	9
5.2.1. Connection of the bar heater (optional scope of delivery)	9
5.3. Water supply / water quality	10
6. Operating the system	11
6.1. Explanation of the operating elements	11
6.2. Functioning of the control system	11
6.3. Error reporting of the control system	12
6.4. Set the sensitivity of the level monitoring relay	12
7. Maintenance	13
7.1. Reset to maintenance state	13
7.2. Cleaning the dust collecting tank	14
7.3. Cleaning of the spark separator	15
7.4. Maintenance of the filling level sensors	15
8. Dismantling / Disposal	16
9. List of spare parts	16
10. Technical data	17
10.1. Technical Data of the bar heater (optional scope of delivery)	17
11. EC declaration of conformity (according to 2001/95/EC)	18
12. Maintenance intervals	19
12.1. Usage-related maintenance	19
12.2. General maintenance	19
12.2.1. Visual inspection of the device	20
12.2.2. Visual inspection of the pipelines for dust deposits	20
12.2.3. Electrical test of the electrical lines and earthing connections	20

1. General

Congratulations on purchasing the product from TEKA.

Our engineers ensure that our devices reflect the state of the art through continuous development. Nevertheless, misuse or misconduct can endanger your safety. Please observe the following for a successful use of the device:

	<p>Only authorised and instructed personnel can carry out transport, operation, maintenance and repair of the device. The operator must ensure that the operating personnel take note of these instructions.</p> <p>Please read these instructions before operating the device, and observe the safety precautions to avoid injury!</p> <p>Store this manual in a safe place! These instructions are to be regarded as a component of the product!</p> <p>Adhere to all product notes!</p> <p>Modifications or conversions that the operator carries out at the device without the consent of the manufacturer, can lead to new safety hazards or to the loss of warranty claims.</p> <p>Observe the manufacturer's instructions. Contact the manufacturer in case of any uncertainty: Tel: +49 2541-84841-0 E-mail: info@teka.eu</p>
---	---

2. Description of the system elements

2.1. Illustration of the system elements

Installation example:

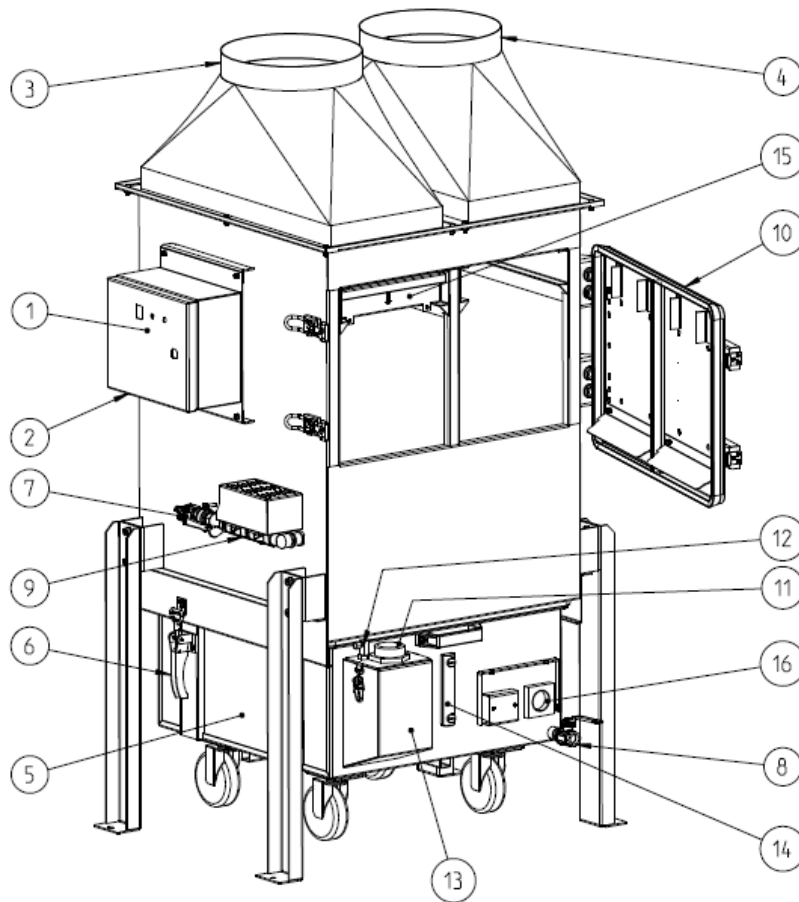

Z.Nr. 11283702

Pos.1	Operating panel of the control	Pos.9	Magnet valve
Pos.2	Connection for mains cable	Pos.10	Service door
Pos.3	Exhaust air nozzle*	Pos.11	Filling level sensor 3-pin
Pos.4	Suction nozzle* (air inlet side)	Pos.12	Filling level sensor 1-pin
Pos.5	Dust collecting tank (filled with water)	Pos.13	Housing for filling level sensor
Pos.6	Toggle lever	Pos.14	Optical filling level indicator
Pos.7	Ball valve 3/4" for water connection	Pos.15	Perforated sheet (exhaust air side)
Pos.8	Wastewater connection 3/4"	Pos.16	Bar heater (option)

* = which is the suction nozzle and which the exhaust air nozzle is defined at the time of assembly (see section "Connecting the suction line and exhaust air line").

2.2. Intended use

The device is intended for commercial use. If the device is made publicly accessible, it must never be operated unsupervised by authorized personnel, authorized by the operator.

The TEKA spark separator is a safety device to protect the filtering unit from sparks and glowing particles, especially during welding. The sparks are extinguished when the air flow strikes the surface of the water. Light particles are also moistened with water through the simultaneous air deflection within the housing.

	WARNING
Dangers arising from fire. If the sucked medium is combustible fume or dust, the operator must determine beforehand which fire protection measures are to be taken.	

3. Safety instructions

3.1. Definition of the hazard symbols

The device is constructed according to the state of the art and the recognised safety regulations. Nevertheless, during use threats to life and limb of the user or other persons may arise. The impairment of the machine or other property are also possible. In these instructions we warn by using corresponding indications.

	WARNING WARNING These instructions are made in case of risks that can lead to <u>injury or death</u> .
---	--

	CAUTION CAUTION These instructions are made in case of risks that can lead to <u>injury</u> .
---	---

	NOTICE NOTICE These instructions are made in case of risks that can lead to <u>material damages</u> .
--	---

	Information notes are no hazard warnings; they call attention to useful information.
---	--

3.2. General safety instructions

	WARNING Dangers arising from improper use / unauthorised operations. The operator must ensure that their authorised personnel are familiar with all the safety indications in this manual in advance. The operator is responsible for ensuring that all work is carried out by authorised and qualified personnel. Laymen are allowed to operate the device after having received the necessary instructions. But they are not allowed to carry out any installation, repair or maintenance work. Dangers arising from fire. In case of fire, if possible, switch the unit immediately off or disconnect it from the power supply. Fire extinguishing measures which the operator is obliged to determine beforehand must be initiated immediately.
---	---

	WARNING Dangers arising from electricity. The operator must ensure that electrical plants and equipment are only built, modified and maintained by a qualified electrician or under the direction and supervision of a qualified electrician. Do not work on components if you are not sure that these are disconnected. If necessary, disconnect the device from the electric power supply and secure it against unauthorized restarting.
---	--

4. Storage, transport and installation of the device

	WARNING
	<p>Risk of injury from tilting or unmounted components when stored or transported. The device must be secured against tilting and slipping when it is stored or transported. Do not stand under or next to the floating load. Lift trucks, forklift trucks and transport cranes must have a sufficient minimum load bearing capacity.</p> <hr/> <p>Dangers arising from tilting or functional impairments at its destination. The unit may only be set up on a suitable surface. The unit may only be set up on a suitable surface. The surface must be vibration-free and horizontal. The operator must check the bearing capacity of the surface. The unit must be secured on the surface, for example using lag bolts or heavy-duty anchors.</p>

	NOTICE
	<p>Damage or functional impairment of the unit due to climatic influences. The unit must be stored in a dry place and protected against moisture during transport. As a matter of principle, the filter unit is not designed to be installed outside. If the unit still be placed in the outdoor area, the dust collecting tank be equipped with a heating element (bar heater, see chapter 2.1). In case of outdoor installation the magnet valve (see chapter 2.1) must also be installed inside the building. The operator has to ensure that the water supply of magnet valve for spark separator remains frost-free. If the unit is placed in the outdoor area, the filter level control must be dismantled and placed indoors. The control and measurement cables to the spark separator are embarrassed to meet new or renew.</p>

5. Commissioning

	WARNING
	<p>Dangers arising from a defective condition of the unit. Make sure that the measures described in this chapter are completed before the commissioning of the unit. All doors of the unit must be closed and all necessary connections must be attached before turning the unit on. Do not operate the unit if any components are defective, missing or damaged. Check the orderly condition of the unit before switching it on.</p>

	NOTICE
	<p>Damaged supply lines. Make sure that the supply lines are protected against damage by forklift trucks and similar events. Protect all supply lines from heat, moisture, oil and sharp edges.</p>

5.1. Connecting the suction line and exhaust air line

For extracting the contaminated air, a suction line must be connected to the suction nozzle (see chapter 2.1).

	CAUTION
<p>Danger for the respiratory tract arising from polluted ambient air. Dust deposits in the suction pipe are possible.</p> <p>Only operate the system if the necessary suction line is fitted. The suction line must be dimensioned according to the application in such a way that, if possible, no dust deposits occur in the suction line. If this has not already been carried out by TEKA, a suitably qualified employee must be consulted. If the suction line includes extraction elements (e.g. suction arms, pipe grills, etc.), these must also be included in the layout. If this is the case then users must be informed of whether extraction elements can be used simultaneously and, if this is possible, then which. The regulating devices (e.g. throttle valves) of each single extraction element must also be set appropriately during the final commissioning.</p>	

The exhaust air pipe must be attached to the exhaust nozzle (see chapter 2.1). (The exhaust air line connects the spark separator to the filter unit.)

5.1.1. Positioning the perforated sheet

If the perforated sheet (see chapter 2.1) is to fulfil its function it must be mounted on the exhaust air side, i.e. on the side on which the exhaust air nozzle is located (see section 2.1). Before taking the equipment into service, it is therefore necessary to check that the perforated sheet is mounted on the correct side.

- Open the service door (see chapter 2.1).
- If this has not already been done, position the perforated sheet on the exhaust air side. Push the perforated sheet fully into the guide.

NOTICE Make sure that the handle is at the front.

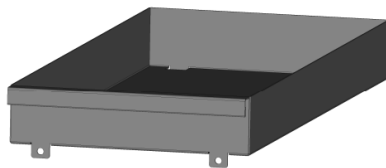

5.2. Electrical connection

	WARNING Risk of electric shock. Electrical plants and equipment may only be built, modified and maintained by a qualified electrician or under the direction and supervision of a qualified electrician. Do not work on live electrical components and elements if you are not sure that these are indeed disconnected. If necessary, disconnect the device from the mains. The operator is responsible for a potential-free balance of the equipment.
---	--

	NOTICE Electric malfunction possible in cause of an incorrect power supply. Pay attention to the admissible supply voltage. Please observe the specifications on the type plate.
---	--

- Connect the mains cable (see chapter 2.1) to the power supply.

5.2.1. Connection of the bar heater (optional scope of delivery)

If the unit is equipped with a heating element (bar heater, see chapter 2.1), then the heating element must still be connected to the power supply.

The bar heater switches on automatically when the water temperature is below +5°C. No more presettings need to be made. The bar heater has an integrated thermostat and works independently of the control.

	NOTICE Electric malfunction possible in cause of an incorrect power supply. Pay attention to the admissible supply voltage. Please observe the specifications of the technical data.
---	--

- Connect the loose cable end of the power plug (A) to the power supply.
- Connect the power plug (A) to the wall device plug (B).

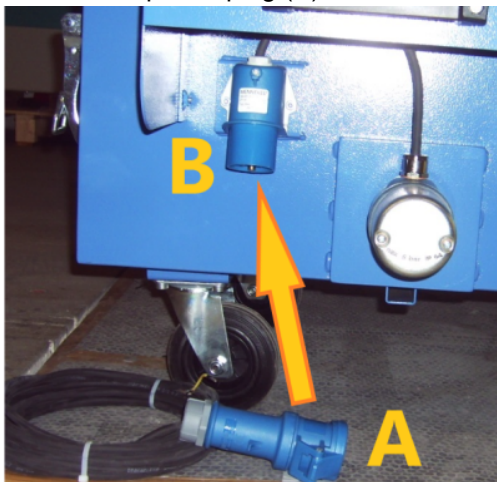

5.3. Water supply / water quality

Due to the moistening of the outlet air, the water is little by little extracted from the filter unit. That is why water must be regularly be refilled. It is ensured by the automatic monitoring of the water level and the automatic refilling through the electrovalve.

	WARNING
	<p>Danger due to unhealthy exhaust air released by contaminated water. Make sure that the supplied water is of irreproachable hygienic and microbiological quality. The supplied water must be clear, colourless and odourless. The water must also be "non-putrefactive in 5 days". Equally, in the event of a system stoppage lasting 5 or more days, the operator must check whether the water still meets the quality requirements or whether it needs to be changed. As soon as an extended stoppage of the system is envisaged, it is urgently recommended to drain off the water for this period. The operator must also make sure that the admixture of the water with the extracted dusts/fumes does not result in any interactions that jeopardize fulfilment of the above quality requirements.</p>



	NOTICE
	<p>Possible damage to equipment (valves, supply line, etc.) due to contaminated water. Make sure that the supplied water is free from suspended matter and other contaminants.</p>

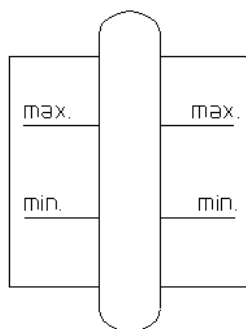

- During operation, the ball valve (see chapter 2.1) has to be equipped with an open water supply of $\frac{3}{4}$ ".
- When carrying out cleaning operations, you have to pay attention that no polluted water enters the canalisation.
- Before switching on the unit for the first time, it is advisable to let in water manually until the water level reaches the middle of the water level indicator.



6. Operating the system

6.1. Explanation of the operating elements

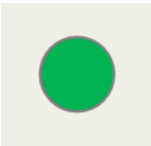
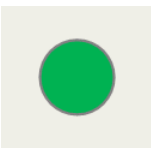
Operating elements for the device control		
Representation	Designation	Description / function
	ON-OFF-switch	By means of this switch, the device is switched on and off. The control is now ready for operation and begins automatically with the level control of the dust collecting tank.  When the device is switched off, it is <u>not</u> disconnected from the power supply.

Operating elements for status and error messages		
Representation	Designation	Description / function
	“Betrieb / Operation”	The light indicator operation gives an optical response when the control is supplied with the mains voltage.
	“Befüllen / Filling”	The light indicator filling gives an optical response when the magnet valve is opened for the filling of the system. The light indicator extinguishes when the maximum nominal level is reached.
	Signal horn	Honking signals that the unit signals an error.

6.2. Functioning of the control system

After switching on the power at a level below the minimum nominal level, the normally open contact of the level monitoring relay goes into the operating position, the magnet valve for the filling of the system is opened and the filling process is started. When reaching the maximum nominal level or after the expiry of the monitoring time the relay is switched off and the magnet valve is closed. If the level is below the minimum nominal level, the relay goes on again and remains engaged till the maximum nominal level is reached.

6.3. Error reporting of the control system

The duration of the valve opening to fill the system is monitored via the time control relay ($t = 30s$). If the maximum nominal level is not reached within a specified period of time, the magnet valve will be closed and an acoustic signal is emitted by the horn. The reset of the malfunction is possible as follows:

- Manual filling of the dust collecting tank till the maximum nominal level is reached.
- Restarting the system.

An acoustic trouble signal by the horn can also be triggered when there is too much water in the spark separator. In this case the filling level sensor has triggered. The reset of the malfunction can be carried out as follows:

- Empty the water to a normal water level. The way of proceeding is described in chapter "Cleaning of the dust collecting tank".
- Restarting of the system.

6.4. Set the sensitivity of the level monitoring relay

The sensitivity of the level monitoring relay is preset by TEKA. In case of exchange or inappropriate switching behaviour of the level monitoring relay the sensitivity must be reset.

- For the commissioning of the level monitoring relay the function FS (pos. 1) is chosen and the sensitivity (pos. 2) is set on the lowest value of 5 k Ω . During that all probes must be immersed in the liquid. The potentiometer for the sensitivity is turned in the direction of 150 k Ω till the monitoring relay is safely switched off and the red LED blinks slowly. Finally it should be checked if the level monitoring relay works as requested.

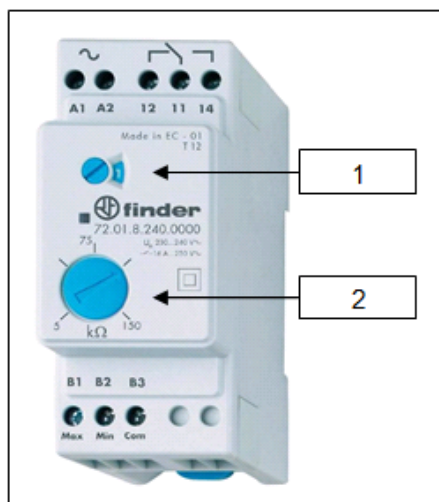



7. Maintenance

In accordance with national regulations, the operator is obliged to carry out repeat and functional tests. Unless otherwise specified by national regulations, we recommend regular visual inspections and functional tests of the device as described in the chapter “Maintenance intervals”.

 You find the chapter “Maintenance intervals” at the end of the document. The general maintenance (visual inspection, etc.) is also explained there.

In this chapter the maintenance work which is caused by wear caused during operation is described.

	<p>WARNING</p> <p>Work on the open system entails the risk of electrical shock or accidental restart the system. Both pose a danger to life and limb.</p> <p>When cleaning and servicing equipment during the replacement of parts or when changing to another function, set the device to maintenance condition first (see chapter “Reset to maintenance state”).</p> <p>A recommissioning of the device must only occur if it is ensured that the device is functionally equivalent to the original state.</p> <hr/> <p>Dangers to life and limb when non-original spare parts are used</p> <p>Only original TEKA spare parts must be used.</p>
---	--

 The operator is obliged to store and dispose of the collected dust in accordance with national or regional regulations. For all maintenance or cleaning work please refer to the applying environmental regulations. Pollutants and filter elements must be disposed of or stored according to the regulations as well. If you have any doubts, we recommend contacting a disposal contractor in your area.

7.1. Reset to maintenance state

- Switch off the unit. Secure the unit against unauthorized restarting during maintenance.
 **WARNING** When the device is switched off, it is not disconnected from the power supply.
- After completion of all maintenance work the unit can be switched on again.

7.2. Cleaning the dust collecting tank

The dust collection container must be cleaned after a certain number of operating hours. This range depends on the amount of dust. The filling level has to be proofed at least once a week.

- The connection of the filling level sensors (see chapter 2.1) has to be dismantled from the housing (see chapter 2.1).
- Only if device is equipped with optional bar heating:
Disconnect the power plug (A) of the heating element from the wall device plug (B) during maintenance.

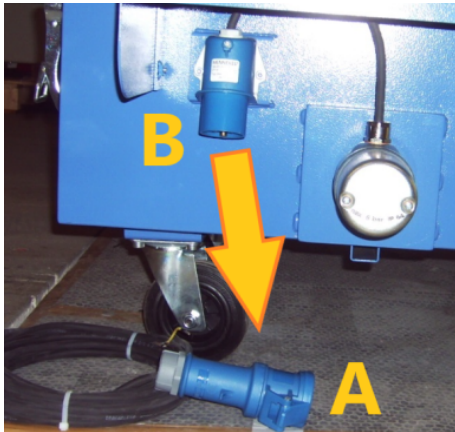

- Open the toggle levers (see chapter 2.1) of the dust collecting tank and pull these out from under the spark separator.
- Open the ball valve (see chapter 2.1) to release the water from the dust collecting tank. A drain hose can be connected to the ball valve. Otherwise position the ball valve over a suitable water drainage device. In case of cleaning work attention should be paid that no water contaminated with pollutants can enter into the sewage system.
- Clean as well the filling level sensor's housing by removing the cap. Pay attention that the measurement electrodes of the sensor are not damaged.
- After cleaning the container push it back under the spark separator and secure with the toggle fasteners. Take care not to damage the gasket.
- The connection of the filling level sensor has to be mounted from the water dust tank.

7.3. Cleaning of the spark separator

- Open the service door (see chapter 2.1) by loosening the locks.
- Make sure that during cleaning processes no polluted water gets into the drainage system.
- Remove all remaining dust particles on the perforated sheet (see chapter 2.1).
- Clean the interior space of the spark separator.
- Reinsert the perforated sheet into the guide rails (exhaust air side) and lock the door.

7.4. Maintenance of the filling level sensors

The filling level sensors (see chapter 2.1) have to be inspected regularly concerning wear and calcination. If necessary the sensors have to be cleaned or changed.

8. Dismantling / Disposal

Only authorised personnel may disassemble the machine.

	WARNING
	<p>Dangers arising from electricity. Before the dismantling of the machine it has to be disconnected from the power supply and all supply lines.</p>

	The operator is obliged to store and dispose of the collected dust in accordance with national or regional regulations.
---	---

9. List of spare parts

	WARNING
	<p>Dangers to life and limb when non-original spare parts are used. Only original TEKA spare parts must be used.</p>

Other parts	Article no.
Magnet valve, 230 V AC	60310340010
Filling level sensor 3-pin	7020210028
Filling level sensor 1-pin	6020210042
for spark separators mit heating element	Article no.
Bar heating 230V 1000W, for FVS 1000-3000, Length 240 mm	6020003008
Bar heating 230V 2000W, for FVS 4000-6000, Length 600 mm	6020003007
Bar heating 230V 3000W, for FVS 7000-12000, Length 880 mm	6020003003

10. Technical data

Version		1000 - 3000	4000 - 6000	7000 - 12000
Control system		Supply voltage: 230 V Frequency: 50 Hz Type of current: L+N+PE		
Width	mm	760	960	1260
Depth	mm	560	760	1060
Height	mm	1450	1450	1450
Weight (without water filling)	kg	ca. 115	ca. 150	ca. 200
Water filling during operation	L	25 - 35	50 - 80	110 - 170
Water supply		Hose nozzle ¾"		
Required water pressure min./max.	bar	0,3 / 16		

10.1. Technical Data of the bar heater (optional scope of delivery)

Version		1000 - 3000	4000 - 6000	7000 - 12000
Supply voltage	V	230	230	230
Heating power	W	1000	2000	3000

11. EC declaration of conformity (according to 2001/95/EC)

TEKA Absaug- und Entsorgungstechnologie GmbH

Millenkamp 9, D-48653 Coesfeld

Tel.: +49 2541-84841-0

E-Mail: info@teka.eu

Internet: www.teka.eu

Designation of the device: TEKA spark separator

We declare under our sole responsibility that the following guidelines have been applied for the above mentioned product:

Electromagnetic Compatibility: 2014/30/EC

Low Voltage Directive: 2014/35/EU

RoHS directive: 2011/65/EU

This declaration will become void if the device is exposed to modifications that are not approved by the manufacturer in written form.

Authorized representative for the technical documentation:

TEKA Absaug- und Entsorgungstechnologie GmbH, Millenkamp 9, D-48653 Coesfeld

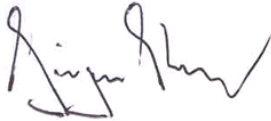

(Jürgen Kemper, managing director)

Coesfeld, 3rd January 2023

12. Maintenance intervals

12.1. Usage-related maintenance

The described maintenances become necessary through the demands of the system operations. The maintenance intervals are recommendations. Depending on the application (multi-shift operation, dust generation, ...) it may make sense for the operator to change the intervals of maintenance, replacing and cleaning.

Maintenance work must always be documented by means of a protocol.

The approach of the maintenance measures is described in chapter "Maintenance".

Maintenance work	Chapter	Maintenance interval	
		recommended by TEKA	determined by the operator
Cleaning the dust collecting tank (or check of fill level)	7.2	weekly	
Cleaning of the spark separator	7.3	monthly	
Maintenance of the filling level sensors	7.4	monthly	

12.2. General maintenance

The described maintenances are independent from the demands of the system operations.

The operator is obliged to carry out repeated inspections and functional tests according to national regulations. If not otherwise covered by national regulations, the described maintenance intervals must be respected.

Maintenance work must always be documented by means of a protocol.

Maintenance work	Chapter	Maintenance interval
Visual inspection of the device	12.2.1	weekly
Visual inspection of the pipelines for dust deposits	12.2.2	monthly
Electrical test of the electrical lines and earthing connections	12.2.3	annually

12.2.1. Visual inspection of the device

Visual inspection: Observation that there are no visible safety-related defects.

	WARNING Danger arising from the ready to operate condition of the device. Follow the procedure as described in the chapter "Set to maintenance state".
---	--

The following steps must be carried out in the course of the visual inspection:

- Check if all required pipeline elements, cable connections and hoses are connected to the filter unit
- Check all electrical earthing connections and cables for visible damages.
- Ensure that all parts are firmly connected.
- Check all metal parts for corrosion or damages / changes of the coating.

12.2.2. Visual inspection of the pipelines for dust deposits

Visual inspection: Observation that there are no visible safety-related defects.

	WARNING Danger arising from the ready to operate condition of the device. Follow the procedure as described in the chapter "Set to maintenance state".
---	--

The following steps must be carried out in the course of the visual inspection:

- Open the inspection flaps of the pipeline and check the pipeline for dust deposits. Dust deposits must be eliminated.

12.2.3. Electrical test of the electrical lines and earthing connections

	WARNING Danger arising from electricity. The operator is responsible for ensuring that all work on electric components is carried out by authorised and qualified personnel.
---	--

The device is subject to regular electrical checks by the operator of the device, and are subject to national standards of the different countries.

The here recommended maintenance interval complies with the in Germany applying "Regulation 3 of the German Social Accident Insurance - Electrical plants and equipment" (formerly known as BGV-A3).

The check must only be carried out by a qualified electrician or a person trained in electrics using suitable measuring and test devices. The scope of testing and the methods must be in line with the respective national standard. All contacts in the control cabinet must be checked for tight fit, and must be readjusted if necessary.